

A. The Algebra of Functions

In our study of functions, we have encountered both numerical and non-numerical functions. Some common functions we have encountered are linear functions, quadratic function, other polynomial functions, rational functions, and functions involving square roots and other roots. Once we have a few basic functions at our disposal, we can build new functions from old ones by combining them using addition, subtraction, multiplication, and division.

Operation	Formula	Domain
Addition: $f + g$	$f + g(x) = f(x) + g(x)$	$(\text{Dom } f) \cap (\text{Dom } g)$
Subtraction: $f - g$	$f - g(x) = f(x) - g(x)$	$(\text{Dom } f) \cap (\text{Dom } g)$
Multiplication: fg	$fg(x) = f(x) \cdot g(x)$	$(\text{Dom } f) \cap (\text{Dom } g)$
Division: $\frac{f}{g}$	$\frac{f}{g}(x) = \frac{f(x)}{g(x)}$	$(\text{Dom } f) \cap (\text{Dom } g) \cap \{x \mid g(x) \neq 0\}$

Another way of building new function from ones is a bit more complicated. The way we make the functions work together is to first put an input into one function. Then, we take the resulting output from the first function and we input it into the second function:

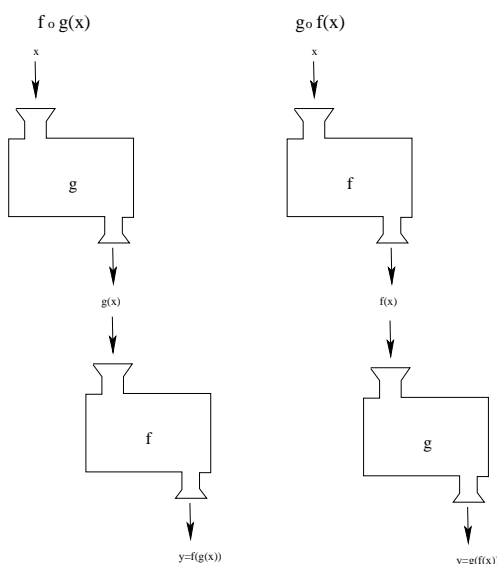

This process is called taking the **composition** of two functions, and the result of this process is called a **composite function**. Symbolically, we write composition as follows:

Operation	Formula	Domain
Composition: $f \circ g$	$f \circ g(x) = f(g(x))$	$(\text{Dom } g) \cap \{x \mid g(x) \in \text{Dom } f\}$
$g \circ f$	$g \circ f(x) = g(f(x))$	$(\text{Dom } f) \cap \{x \mid f(x) \in \text{Dom } g\}$

Examples:

1. Let $f(x) = 2x + 1$ and $g(x) = x^2 - 1$

(a) $f + g(x) = (2x + 1) + (x^2 - 1) = x^2 + 2x$

(b) $f - g(x) = (2x + 1) - (x^2 - 1) = -x^2 + 2x + 2$

(c) $fg(x) = (2x + 1)(x^2 - 1) = 2x^3 + x^2 - 2x - 1$

(d) $\frac{f}{g}(x) = \frac{2x+1}{x^2-1}$ [Domain: $x \neq \pm 1$]

(e) $f \circ g(x) = f(g(x)) = 2(g(x)) + 1 = 2(x^2 - 1) + 1 = 2x^2 - 1$

(f) $g \circ f(x) = g(f(x)) = (f(x))^2 - 1 = (2x + 1)^2 - 1 = 4x^2 + 4x$

2. Given that $h(x) = \sqrt{3x^2 + 4}$, write h , find functions f and g so that $h = f \circ g$.

$f(x) = \sqrt{x}$ and $g(x) = 3x^2 + 4$

or

$f(x) = \sqrt{3x + 4}$ and $g(x) = x^2$

or ... (there are many ways to do this)

3. Here an more complicated way of combining a function with itself. We will use this more later in the course:

Let $f(x) = x^2 + 2x + 3$. Find $\frac{f(a+h) - f(a)}{h}$.

$f(a) = a^2 + 2a + 3$

$f(a+h) = (a+h)^2 + 2(a+h) + 3 = x^2 + 2ah + h^2 + 2a + 2h + 3$, so

$$\begin{aligned} \frac{f(a+h) - f(a)}{h} &= \frac{(a^2 + 2ah + h^2 + 2a + 2h + 3) - (a^2 + 2a + 3)}{h} \\ &= \frac{a^2 + 2ah + h^2 + 2a + 2h + 3 - a^2 - 2a - 3}{h} = \frac{2ah + h^2 + 2h}{h} = 2ah + h + 2 \end{aligned}$$