

Ch. 9 Stereochemistry

- Stereoisomers have the same condensed formulas and basic bonding sequence, but have different 3-dimensional shape and cannot be interconverted

9.1.2 Chirality

chiral-equivalent to "handed". A molecule is chiral if it is not superimposable on its mirror image.

achiral- A molecule is achiral if it is the same as its mirror image.

enantiomers-Two molecules that are mirror images of each other but are different and are not superimposable on each other.

- Note: "enantiomers" involves a relationship between two structures.
- "Chiral" is a term that applies to a single molecule.

Drawing Mirrors/Enantiomers: **Exchange of any two attachments** inverts the stereochemistry and produces a mirror image of the original:

- front and back (hashes and wedges)
- left and right (while keeping your hashed and wedged attachments unchanged)
- flipping something on a side (could be the left side or the right side) with the hashed position in back

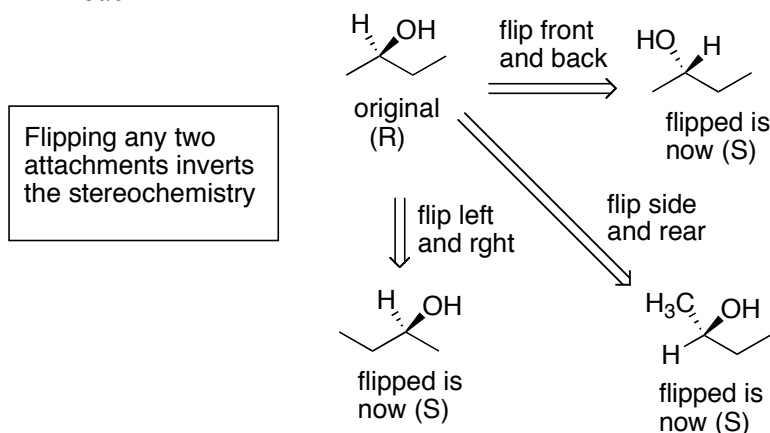

chiral carbon (or stereocenter or asymmetric carbon atom)-an atom bearing groups such that interchange of 2 of the groups produces a stereoisomer. Any tetrahedral atom that has four different attached groups is a chiral carbon.

Recognizing Chiral Molecules: Key is to look for chiral carbons/stereocenters

- If **zero** chiral carbons → molecule is **achiral**
- If **one** chiral carbons → molecule is **chiral**
- If **two** (or more) chiral carbons → molecule may be **chiral or achiral**
 - if it has no plane of symmetry under any conditions, it is chiral.
 - If it has a plane of symmetry (in one conformation or drawing perspective) → achiral
 - if a molecule has ≥ 2 chiral carbons but is achiral with a plane of symmetry, it is called a **meso** compound
 - to recognize whether a molecule with ≥ 2 chiral carbons is achiral or chiral, try to draw it in a way such that the carbons are maximally symmetrical, so that it will be easiest to see whether or not a plane of symmetry exists. This may sometimes involve using a sawhorse rather than a zig-zag picture to maximize the ease of seeing potential symmetry.

1. Classify as Chiral or Achiral

a.



b.



c.

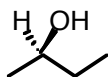

d.

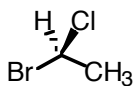

e.

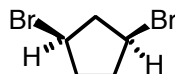

f.

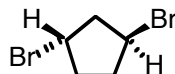

g.

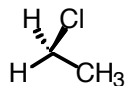

h.

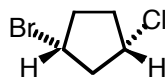

2. What is the Relationship Between the Following Pairs of Structures. Are they the same, or enantiomers?

a.

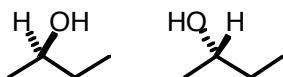

b.

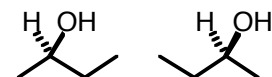

c.

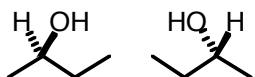

d.



e.



f.

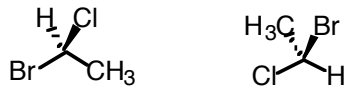

f.



3. Identify each stereocenter with an asterisk, then classify the configuration of each stereocenter as (R) or (S). (Can do the same with the structures in problems 1 and 2)

a.



b.

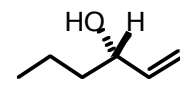

c.

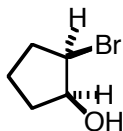

d.

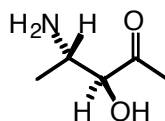

9.5 R/S Classification for Chiral Carbons

1. Assign Priority of Atoms/Groups attached to a tetrahedral stereocenter (1 highest, 4 lowest)
 - a. For different elements, higher atomic number takes priority
 - Halogen > Oxygen > Nitrogen > Carbon > Hydrogen
 - b. In case of carbon versus carbon ties: Differentiate at nearest point of difference
 1. A carbon with a heteroatom attached beats one without
 2. For carbons with no heteroatoms, one with more H's loses to one with less
 - 3° carbon > 2° carbon > 1° carbon > CH₃
 - c. Handling double bonds and triple bonds
 - A carbon with more H's again loses to one with fewer
 - Double or triple bonds are treated as if each of the bonds has extra C's attached

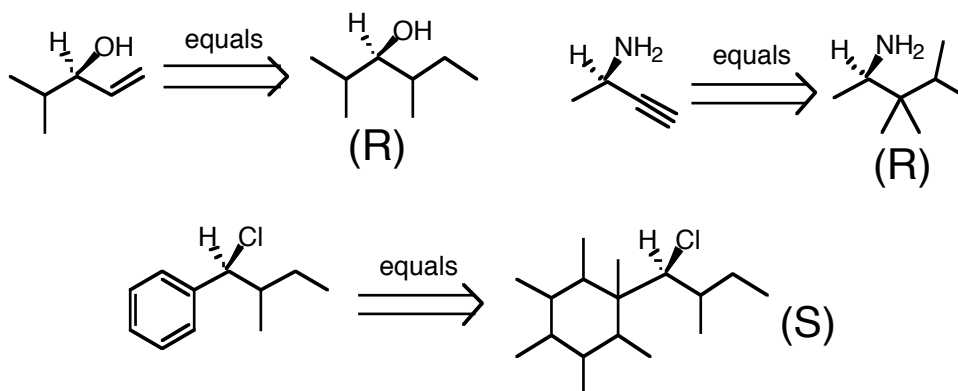

2. If the low priority group 4 (normally H) is in the back (hashed), trace a path from 1 → 2 → 3.
 - a. If the path goes clockwise, the stereocenter is (R)
 - b. If the path goes counterclockwise, the stereocenter is (S)
3. If the low priority group 4 (normally H) is in front (wedged), then the situation is reversed.
 - a. If the path goes clockwise, the stereocenter is (S)
 - b. If the path goes counterclockwise, the stereocenter is (R)
4. If the low priority group 4 (normally H) is to the left or to the right, exchange it with the group in the back (hashed), and trace the path on the resulting figure.
 - a. If the path in the redrawn picture goes clockwise (R), the original stereocenter is (S)
 - b. If the path in the redrawn picture goes counterclockwise (S), the original stereocenter is (R)
5. In Fisher projections, since H is always in front, clockwise is (S) and counterclockwise is (R)

Drawing Structure, Given Name: Draw the easiest one, with H in back. If correct, great! If incorrect, simply redraw with the H in front.

Ex: Draw (R)-3-chloroheptane

9.3,4,9,10 Enantiomers and How They Differ

- Enantiomers have indistinguishable properties in most ways:
 - Melting points
 - Boiling points
 - Solubility
 - Density
 - Chemical reactivity towards achiral reactants.

Enantiomers Differ in 2 Ways1. Reactivity with Chiral Chemicals (Major chemistry difference)

- Enzymes are like left-handed gloves, which routinely select left-handed over right-handed enantiomers
- An achiral molecule is like a mitten that fits a left hand or right hand equally well.

Chiral reactants discriminate between enantiomers and react with one faster than the other

Achiral reactants do not discriminate between enantiomers and react equally with either one

2. Optical Activity: Enantiomers Rotate the Plane of Polarized Light in Opposite Directions (Major Diagnostic difference)

- **“Optically Active”**: A solution is optically active if it rotates polarized light
- Enantiomers rotate light in equal but opposite directions
- **“Optically Inactive”**: A solution is optically inactive if it does not rotate light
- Note: optical activity is a property of a bulk solution, not an individual molecule
- A bulk solution is optically active if it has an excess of one enantiomer

Two Ways to Be Optically Inactive

1. If the solution has no chiral molecules present, or
 2. If the solution has a 50/50 mixture of chiral enantiomers (a “racemic mixture”)
- **Note: While to be “optically active” does indicate the presence of chiral molecules, to be “optically inactive” does not prove the absence of chiral molecules! It only means that there is no excess of one enantiomer over the other!**

Q: Classify each of the following as “optically active” or “optically inactive”

1. A solution of 1-bromopropane.
2. A solution with equal quantities of (R)-2-bromobutane and (S)-2-bromobutane
3. A solution of pure (R)-2-bromobutane
4. A solution with 80% (R)-2-bromobutane and 20% (S)-2-bromobutane
5. If pure (R)-2-bromobutane rotates light 100° to the right, what would happen to light applied to pure (S)-2-bromobutane?
6. If pure (R)-2-bromobutane rotates light 100° to the right, how much rotation would occur for a solution with 80% (R)-2-bromobutane and 20% (S)-2-bromobutane

9.10 Racemic Mixtures

- **Racemic mixture**-a solution containing an equimolar, 50/50 mixture of enantiomers.
 - A racemic mixture is optically inactive.
 - It will not rotate light because the enantiomers cancel each other out.
 - But a racemic mixture is still “chiral”.
 - Other aliases: racemic, racemic mix, racemate, a (\pm) pair, a (*d,l*) pair
- **The vast majority of solutions containing chiral molecules are racemic.**

1. Most reactions that produce chiral molecules provide a racemic, 50/50 mixture of enantiomers

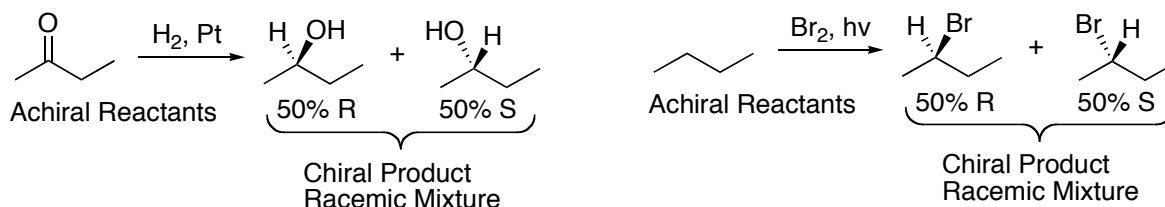

2. For chiral molecules, assume a racemic mixture unless told otherwise

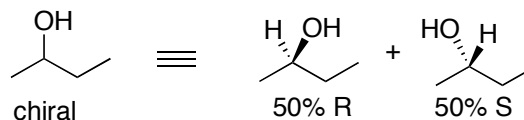
Enantiomeric Excess (“ee”) and Optical Purity

- **enantiomeric excess (ee)** = [(mole fraction major enantiomer)-(mole fraction minor enantiomer)] x 100
- **optical purity** = [observed rotation/rotation of pure enantiomer] x 100
- Note: Enantiomeric excess and optical purity values are exactly the same, but are used depending on the experimental method of measurement. Enantiomeric excess is used when you determine the mole/mole ratio of enantiomers by NMR or some other method; optical purity is used when you use optical rotation to characterize a solution containing a mixture of enantiomers.

Problem: A solution has 80% (R)-2-bromobutane and 20% (S)-2-bromobutane

1. What is the “enantiomeric excess” of (R)-2-bromobutane?
2. If pure (R)-2-bromobutane rotates light 100° to the right, how much rotation would occur for a solution with 80% (R)-2-bromobutane and 20% (S)-2-bromobutane
3. If a solution has a 50/50 mixture of (R)- and (S)-2-bromobutane, what would be the enantiomeric excess and the optical purity?
4. If a solution has a 50% ee, what would be the ratio of enantiomers?
 - a. 50% R, 50% S or
 - b. 75% R, 25% S

Chirality and Conformations

- Avoid conformational pictures, which may deceptively give the appearance of chirality

If any conformation or drawing of a molecule has a symmetry plane, it is achiral

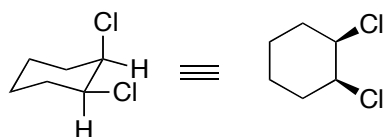
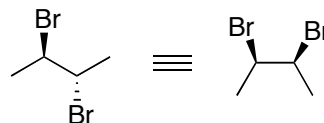
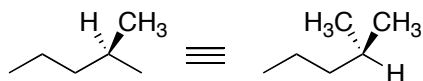
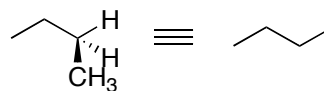
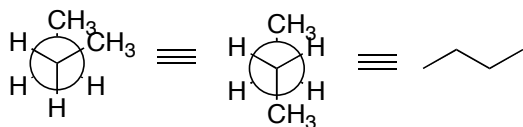
Freaks: Chiral Compounds without Chiral Carbons: Not Tested

Ex: Allenes

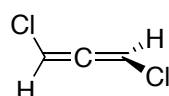
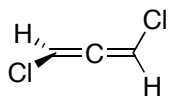

Mirror images are not superimposable

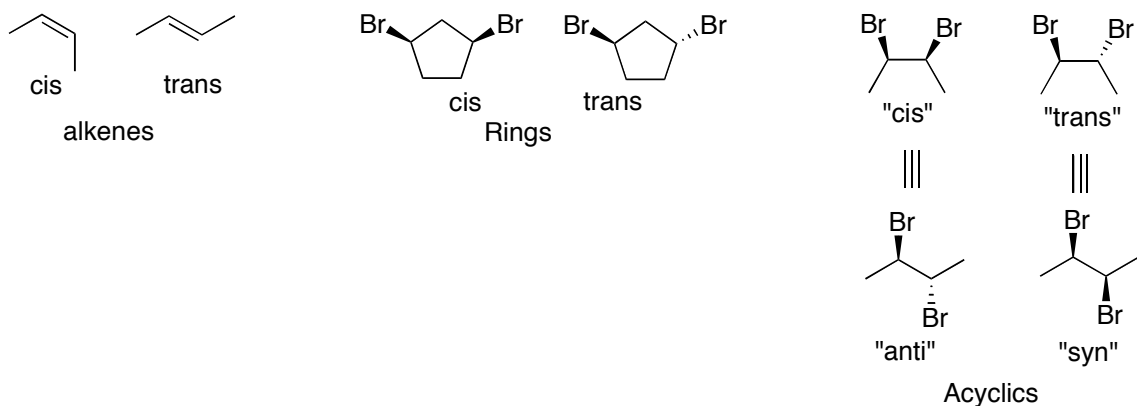
9.6 Diastereomers: Cis/Trans Stereoisomers that are **Not** Enantiomers

- Note: for acyclics you can rotate around and have different looks for the same molecule, depending on whether you're eclipsed or zig-zagged relative to the single bonds.
- Be consistent. If you zig-zag one, zig-zag the other. If you eclipse one, eclipse the other.
- Normally, for stereo questions, the zig-zag layout isn't conducive to recognizing symmetry.
- So for stereo questions, the more symmetric eclipsed layout is preferable
- Non-test note: Cis or trans is unambiguous for alkenes and rings, but not for acyclics. Often "syn" or "anti" is used instead, assuming the zig-zag layout.

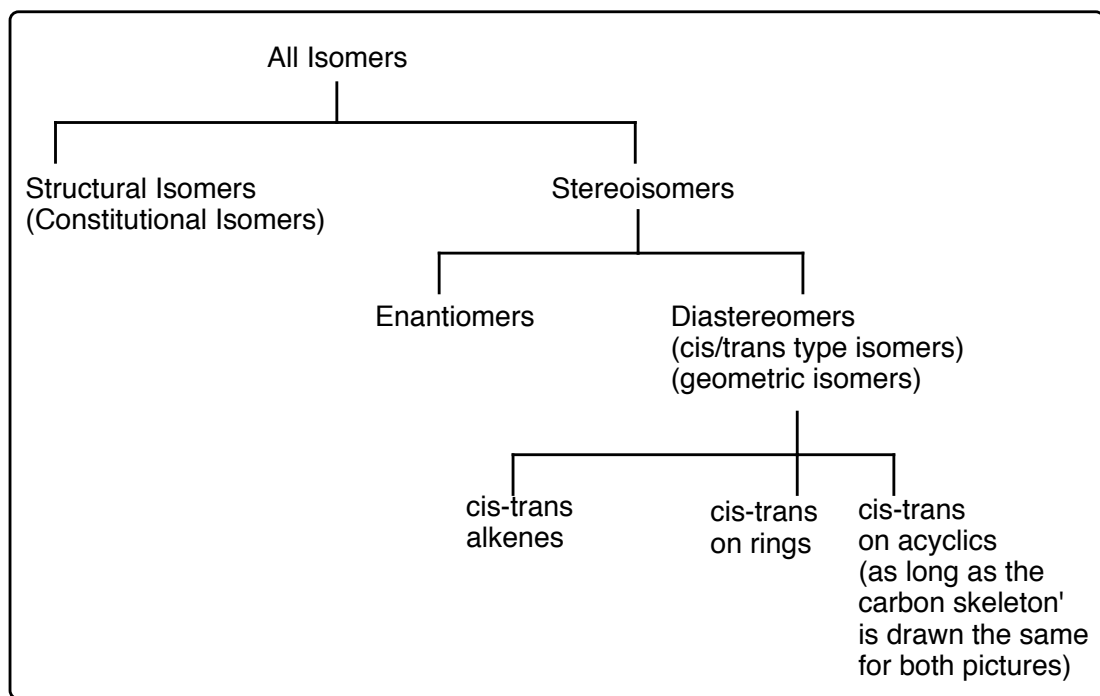
Summary: Types of Isomers (9.11)

9.6-8 Molecules with ≥ 2 Chiral Carbons

- **Rule: The maximum number of potential stereoisomers = 2^n (n = number of chiral carbons)**
- Remember: If a molecule can be drawn with a plane of symmetry, then it is achiral and its mirror image will be the same as the original.
- If one possible isomer is achiral, then you won't get the maximum number of unique stereoisomers because two of them will be identical mirror images
- **Suggestion: Try to draw molecules so as to maximize symmetry, regardless of actual conformational stability. This may often involve drawing an eclipsed picture rather than zig-zag**

Problem:

- a. Draw all unique stereoisomers of 2-bromo-3-chlorobutane.
- b. Identify each picture with a Letter (A, B, etc.), and then specify the relationships between each pair as either same, enantiomers, or diastereomers.
- c. Identify each picture as chiral or achiral (meso)

9.7 Meso Compounds

- **meso compound**-an achiral, optically inactive molecule that contains tetrahedral stereocenters (usually two). Both of the Br-bearing carbons in cis-1,2-dibromocyclopentane are stereocenters, but the molecule itself has a plane of symmetry and is achiral.

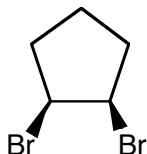

meso, has stereocenters but is achiral due to plane of symmetry

- Remember: If a molecule can be drawn with a plane of symmetry, then it is achiral and its mirror image will be the same as the original.
- Meso compounds always involve 2 (or more) chiral carbons. Never just one.
- When a meso structure is involved, you won't get the maximum 2^n th number of stereocenters
- Suggestion: Try to draw molecules so as to maximize symmetry, regardless of actual conformational stability. This may often involve drawing an eclipsed picture rather than zig-zag
- **A meso compound will not have an enantiomer**
- To draw an enantiomer, invert **all** hash/wedges (but be sure you're chiral to begin with)
- To draw a diastereomer, invert one but not both hash/wedges

1. Problem:

- Draw all unique stereoisomers of 2,3-dibromobutane.
- Identify each picture with a Letter (A, B, etc.), and then specify the relationships between each pair as either same, enantiomers, or diastereomers.
- Identify each picture as chiral or achiral (meso)

- Draw all unique stereoisomers of 2,3-dibromopentane. Identify each picture with a Letter (A, B, etc.), and then specify the relationships between each pair as either same, enantiomers, or diastereomers. Identify each picture as chiral or achiral (meso)

3. Draw all unique stereoisomers of 2,4-dibromopentane. Identify each picture with a Letter (A, B, etc.), and then specify the relationships between each pair as either same, enantiomers, or diastereomers. Identify each picture as chiral or achiral (meso)

4. Draw all unique stereoisomers of 2,4-dibromocyclopentane. Identify each picture with a Letter (A, B, etc.), and then specify the relationships between each pair as either same, enantiomers, or diastereomers. Identify each picture as chiral or achiral (meso)

5. Identify each picture as chiral or meso

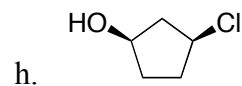
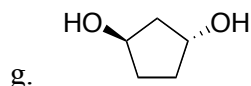
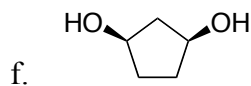
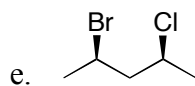
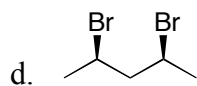
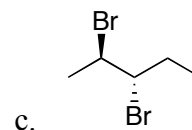
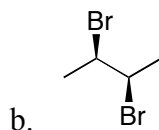
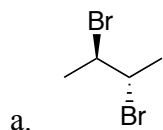

Absolute and Relative Configuration

Absolute: (R) or (S)

Relative: Comparison between 2 molecules or 2 chiral carbons (even if we don't know absolute)

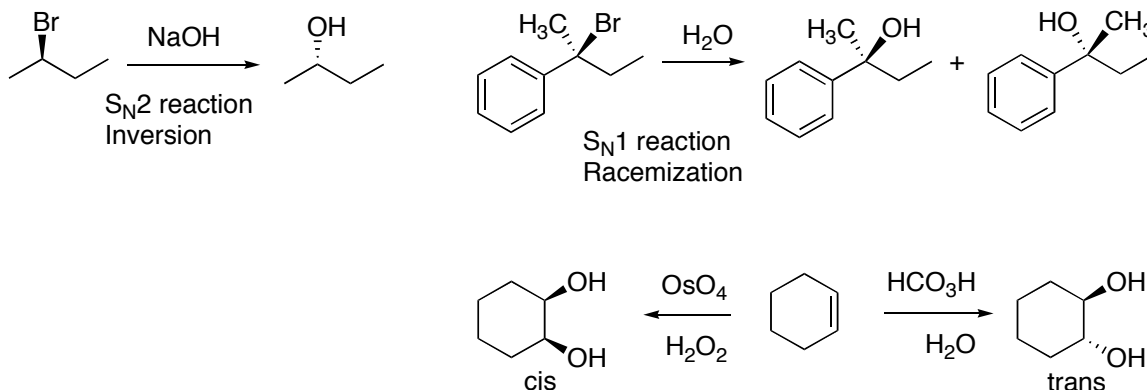

- Relative stereochemistry is often an important feature in mechanisms and product predictions

9.6 Diastereomers Differ in Physical Properties (Unlike Enantiomers)

- Diastereomers have different melting points, boiling points, solubilities, etc. (unlike enantiomers)

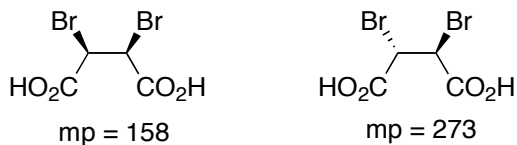

9.10 Separation of Enantiomers via Diastereomers

- Enantiomers can be separated by temporary attachment to an optically active thing \rightarrow resulting in separable diastereomers \rightarrow chop attachment following separation

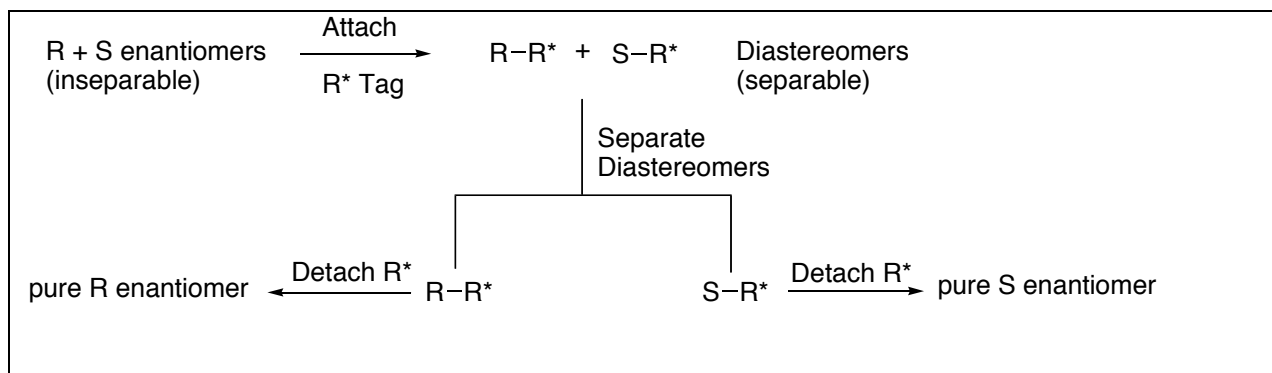

Chem 350 Chapter 9 Stereochemical Terminology Summary Terms and Definitions

Classification of Isomers

isomers-different compounds with the same molecular formula.

structural isomers (or constitutional isomers)-isomers that have their atoms connected in a different order.

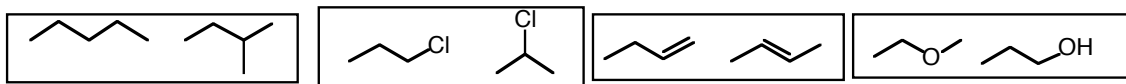

stereoisomers (or configurational isomers)-isomers in which atoms are joined in the same order but differ in the way their atoms are arranged in space. Stereoisomers are subdivided into two categories: **enantiomers** and **diastereomers**.

conformations-easily interconverted by σ -bond rotation or cyclohexane chair flips. In butane, for example, the gauche, eclipsed, and staggered forms are considered to be different **conformations**; in cyclohexanes, the two chairs are conformations. Different conformations are not considered stereoisomers.

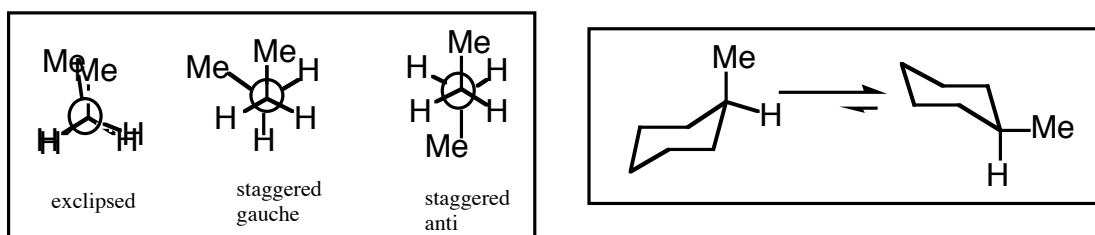

Summary: Types of Isomers

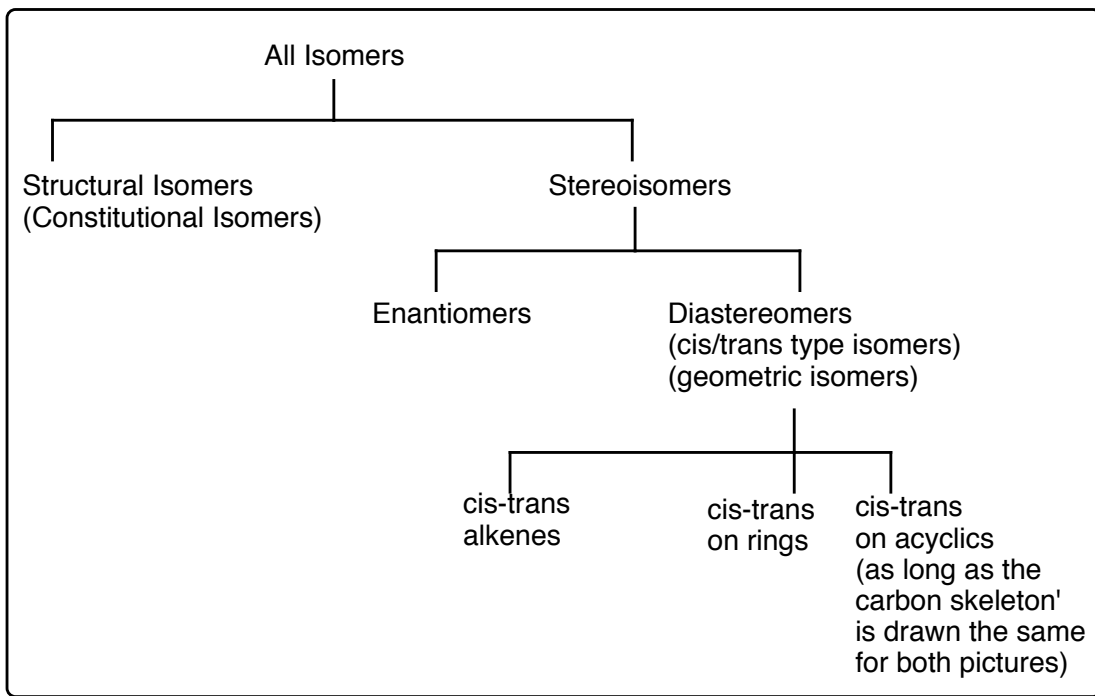

Classification of Stereoisomers

enantiomers-stereoisomers that are not superposable on their mirror reflections. Ex. (R)-2-bromobutane and (S)-2-bromobutane. Separate enantiomers rotate polarized light and are said to be optically active.

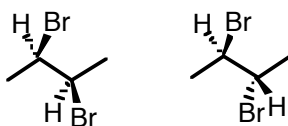

diastereomers-stereoisomers that are not enantiomers, that is, not mirror images of each other. Ex. cis- and trans-2-butene; cis- and trans-1,3-dimethylcyclopentane; (2R)-(3R)-2-bromo-3-chlorobutane and (2R)-(3S)-2-bromo-3-chlorobutane. Diastereomers are cis/trans-type isomers, although isomers such as those drawn below are sometimes called syn/anti instead. If the carbon skeletons are drawn analogously, two molecules whose hash/wedge attachments have a cis-trans type relationship will be diastereomers.

Miscellaneous Stereochemical Terms

chiral-equivalent to "handed". A molecule is chiral if it is not superimposable on its mirror image; an achiral molecule is superimposable on its mirror image.

chiral carbon (or stereocenter or asymmetric carbon atom)-an atom bearing groups such that interchange of 2 of the groups produces a stereoisomer. Any tetrahedral atom that has four different attached groups is a chiral carbon.

- Most molecules containing tetrahedral stereocenters are chiral (the exception being "meso compounds".) The configuration of a tetrahedral stereocenter can be designated as (R) or (S).

configuration-the particular arrangement of atoms in space that is characteristic of a given stereoisomer. The configuration of each stereocenter can be designated as (R) or (S).

racemic mixture-a 50/50 mixture of two enantiomers that will not rotate light.

meso compound-an achiral, optically inactive molecule that contains tetrahedral stereocenters (usually two). Both of the Br-bearing carbons in cis-1,2-dibromocyclopentane are stereocenters, but the molecule itself has a plane of symmetry and is achiral.

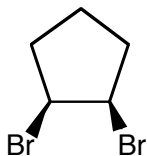

meso, has stereocenters but is achiral due to plane of symmetry

R/S Classification for Chiral Carbons

1. Assign Priority of Atoms/Groups attached to a tetrahedral stereocenter (1 highest, 4 lowest)
 - a. For different elements, higher atomic number takes priority
 - Halogen > Oxygen > Nitrogen > Carbon > Hydrogen
 - b. In case of carbon versus carbon ties: Differentiate at nearest point of difference
 1. A carbon with a heteroatom attached beats one without
 2. For carbons with no heteroatoms, one with more H's loses to one with less
 - 3° carbon > 2° carbon > 1° carbon > CH₃
 - c. Handling double bonds and triple bonds
 - A carbon with more H's again loses to one with fewer
 - Double or triple bonds are treated as if each of the bonds has extra C's attached

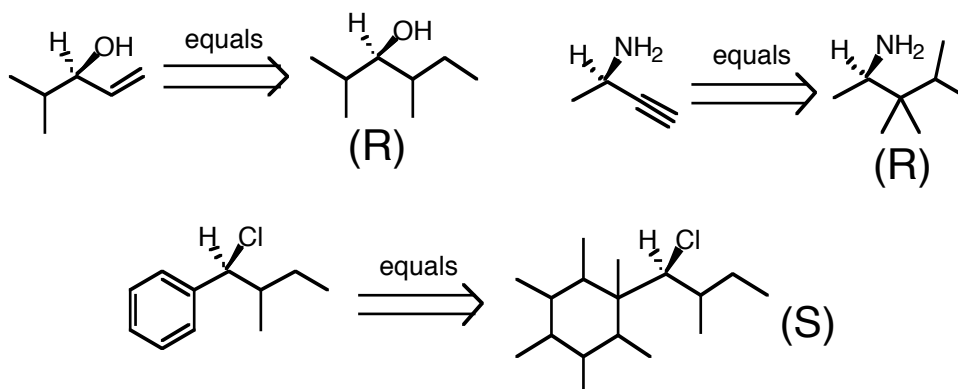

2. If the low priority group 4 (normally H) is in the back (hashed), trace a path from 1 → 2 → 3.
 - d. If the path goes clockwise, the stereocenter is (R)
 - e. If the path goes counterclockwise, the stereocenter is (S)
3. If the low priority group 4 (normally H) is in front (wedged), then the situation is reversed.
 - f. If the path goes clockwise, the stereocenter is (S)
 - g. If the path goes counterclockwise, the stereocenter is (R)
4. If the low priority group 4 (normally H) is to the left or to the right, exchange it with the group in the back (hashed), and trace the path on the resulting figure.
 - h. If the path goes clockwise, the stereocenter is (S)
 - i. If the path goes counterclockwise, the stereocenter is (R)
5. In Fisher projections, since H is always in front, clockwise is (S) and counterclockwise is (R)

Drawing Mirrors/Enantiomers: Exchange of any two attachments inverts the stereochemistry and produces a mirror image of the original:

1. front and back (hashes and wedges)
2. left and right (while keeping your hashed and wedged attachments unchanged)
3. flipping something on a side (could be the left side or the right side) with the hashed position in back

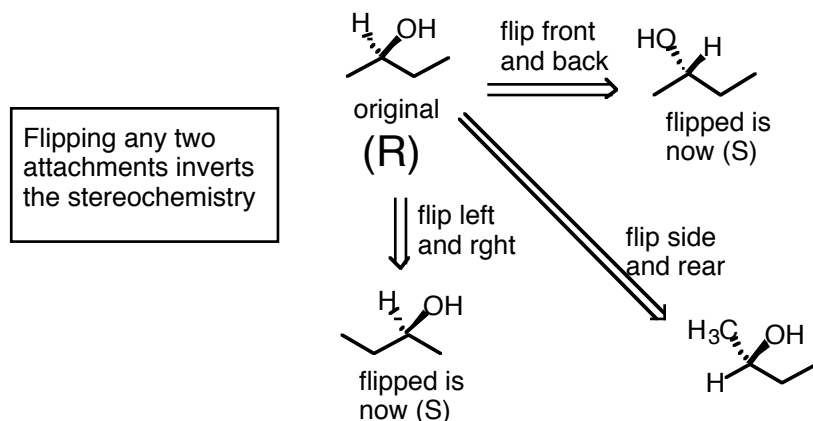

Recognizing Chiral Molecules: Key is to look for chiral carbons/stereocenters

1. If **zero** chiral carbons → molecule is **achiral**
2. If **one** chiral carbons → molecule is **chiral**
3. If **two** (or more) chiral carbons → molecule may be **chiral or achiral**
 - e. if it has no plane of symmetry under any conditions, it is **chiral**.
 - f. If it has a plane of symmetry (in one conformation or drawing perspective), then it is **achiral**
 - g. if a molecule has ≥ 2 chiral carbons but is achiral with a plane of symmetry, it is called a **meso** compound
 - h. to recognize whether a molecule with ≥ 2 chiral carbons is achiral or chiral, try to draw it in a way such that the carbons are maximally symmetrical, so that it will be easiest to see whether or not a plane of symmetry exists. This may sometimes involve using a sawhorse rather than a zig-zag picture to maximize the ease of seeing potential symmetry.

Terminology Related to Enantiomeric Purity

enantiomeric excess (ee) = [(mole fraction major enantiomer)-(mole fraction minor enantiomer)] x 100

optical purity = [observed rotation/rotation of pure enantiomer] x 100

Note: Enantiomeric excess and optical purity values are exactly the same, but are used depending on the experimental method of measurement. Enantiomeric excess is used when you determine the mole/mole ratio of enantiomers by NMR or some other method; optical purity is used when you use optical rotation to characterize a solution containing a mixture of enantiomers.

racemic mixture-an equimolar mixture of enantiomers. A racemic mixture will not rotate light.

Fischer Projections

In Fischer projections, atoms attached to horizontal lines are viewed as being in front of the plane (wedged), and atoms attached to vertical lines are viewed as being behind the plane (wedged). In the following pictures, Et=ethyl, Me=methyl.

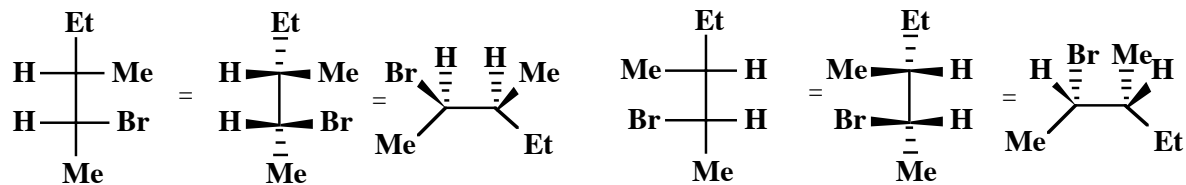
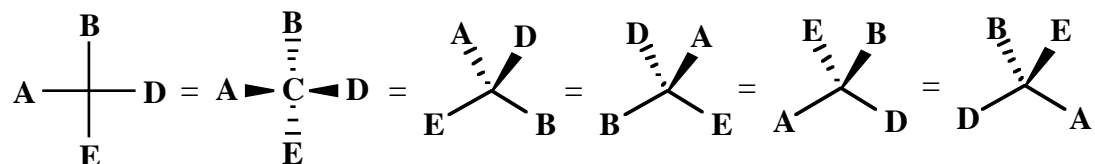

The two structures shown above are enantiomers

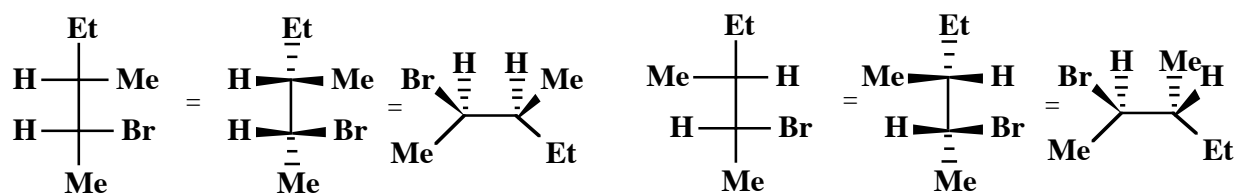

The two shown here are diastereomers.

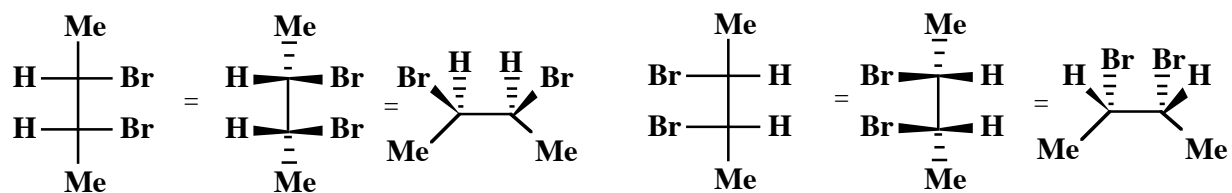

The two shown here are not stereoisomers; they are "meso compounds", because there is a plane of symmetry.